

# Receding-Horizon Optimal Control for Container Transfer in Intermodal Terminals

Angelo Alessandri\*

Simona Sacone†

Silvia Siri†

\*Institute of Intelligent Systems for Automation  
ISSIA-CNR National Research Council of Italy  
Via De Marini 6, 16149 Genova, Italy  
angelo@ge.issia.cnr.it

†Dept. of Communications, Computer and Systems Sciences  
DIST-University of Genova  
Via Opera Pia 13, 16145 Genova, Italy  
{simona,silvia\_siri}@dist.unige.it

## 1 Introduction

A major feature of intermodal transportation systems is the presence of large container terminals, where loading and unloading of containers are split in different tasks that depend on carrier categories, cargo types and service requirements. The efficiency of a terminal is influenced by the ability to manage the various transfer tasks done by means of quay cranes, transfer cranes, trucks and so on. The terminal resources and their utilizations can be suitably modelled and optimized to improve the overall system productivity. In this context, two main research issues arise, relevant to the definition of suitable models for terminal operations and to the use of such models to find a decision strategy for controlling container transfers inside the terminals.

The literature on modelling of intermodal operations is quite recent. Different types of models have been proposed: basic simulation models [2, 4], generic discrete-event systems [6, 7] and multi agents [5]. Clearly, the choice of a model has to be made depending on the required level of detail, as well as on the specific goals of performance evaluation and decision support [8]. As a matter of fact, every modelling paradigm is affected by both advantages and drawbacks. For example, event-driven models allow to obtain a precise description of overall terminal operations but are unsuitable to synthesize a control strategy, which, on the contrary, can be more easily addressed by means of aggregate models.

In this paper, a different approach is followed that consists in using an “ad hoc” developed model which constitutes the basis for defining an optimal control strategy. Specifically, the proposed model is based on a set of queues; each queue represents a different container allocation stage in the area of the terminal, where containers are stored, depending on the transport

modality and routing. The dynamic evolutions of such queues are described by discrete-time equations, where the control variables take into account the utilization of terminal resources as load/unload capabilities and the available yard space. An optimal control problem is stated that consists in minimizing the transfer delays of containers in the terminal. A receding-horizon strategy is proposed for the solution of such control problem.

## 2 The model of intermodal terminal operations

A general structure of maritime container terminals is depicted in Fig.1. Different areas can be identified in the proposed structure: a quay is a part of the terminal devoted to handling operations with containership. Analogously, gates for trains and trucks are present in the terminal.

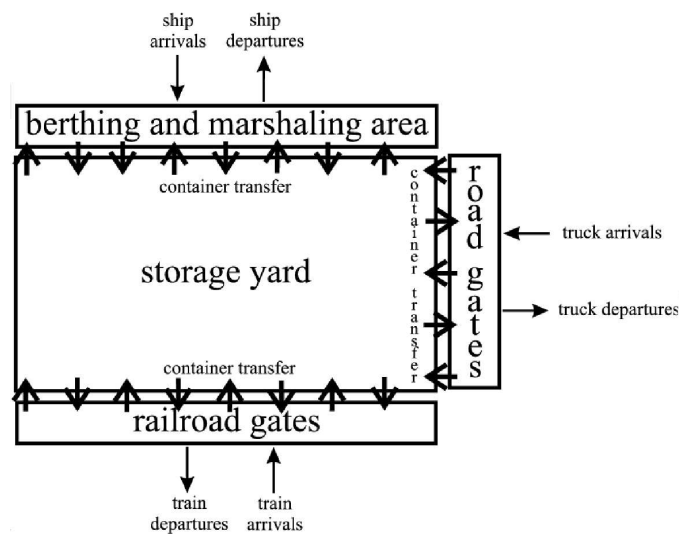

Figure 1: Layout of a container terminal.

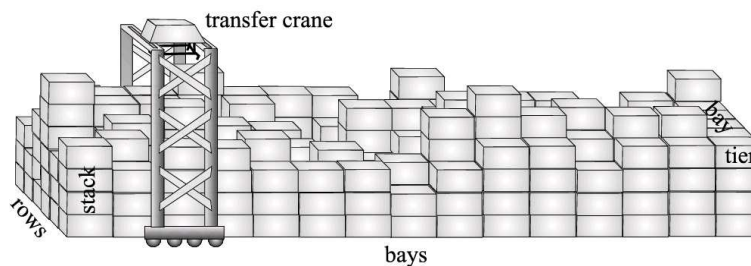

Figure 2: Block of a container yard.

The yard is the central storage area typically divided in blocks, where containers are piled up, as shown in Fig. 2. The transfer machines operating in the yard are quay cranes, transfer cranes, stackers and yard trucks. In the considered kind of container terminal, the storage yard also includes a dedicated area where containers are opened and goods inside containers are processed before being stocked again. As already mentioned, the overall container terminal

is modelled by representing the different physical areas as buffers. Fig. 3 describes pictorially the proposed model.

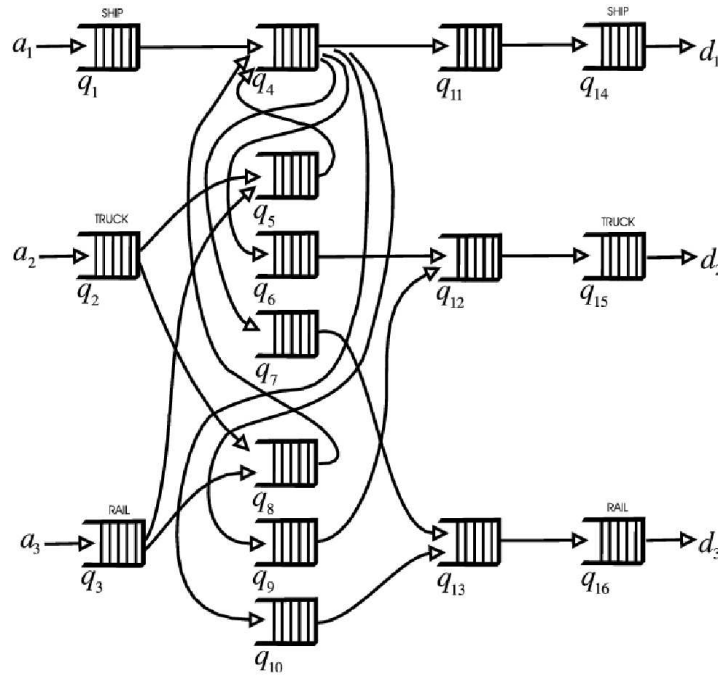

Figure 3: Queue model of the intermodal terminal operations.

The arrivals of containers at the terminal by ship, road and rail are represented by quantities  $a_1$ ,  $a_2$  and  $a_3$ , respectively. Analogously, quantities  $d_1$ ,  $d_2$  and  $d_3$  model the departures of containers from the terminal by ship, road and rail. When a containership reaches the terminal, the unloading process is modelled by a queue, which has a length at time  $t$  denoted by  $q_1(t)$  in TEUs. The containers in this queue are routed to the same transport mode (transshipment) or to the other ones. Similarly, containers arriving by road and rail are buffered in the queues  $q_2$  and  $q_3$ : the direction of transfer is only for ship export through queue  $q_4$ , as we deal with a maritime terminal. Differently from  $q_1$  and  $q_3$ ,  $q_2$  does not model unloading operations, but represents the waiting time of the trucks at the gates. As a matter of fact, trucks are able to transport containers directly to the yard.

The containers temporary storage is made by means of the queue  $q_4$  in the quay and by the queues  $q_5, q_6, q_7, q_8, q_9$ , and  $q_{10}$  in the yard. Buffer  $q_4$  models the presence of containers in the quay waiting for being loaded on a ship,  $q_5, q_6$  and  $q_7$  are queues for containers that are stored in the yard and will be loaded on ship, truck and rail respectively, while  $q_8, q_9$  and  $q_{10}$  are queues for containers that are going to be loaded on ship, truck and rail respectively but need to be opened and worked in the yard. The export buffering is represented by means of the queues  $q_{11}, q_{12}, q_{13}, q_{14}, q_{15}$ , and  $q_{16}$ . In particular,  $q_{11}$  and  $q_{13}$  represent queues for loading operations to ship and rail,  $q_{12}$  represents the waiting time of outgoing trucks at the gate, whereas  $q_{14}, q_{15}$ , and  $q_{16}$  model the departure of these means of transport, when their level of storage is exactly equal to the external demand  $d_i(t)$ .

A complete model of the transfer activities in the terminal is described by the following

discrete-time equations:

$$\begin{aligned}
q_1(t+1) &= q_1(t) + \Delta T [a_1(t) - \mu_1 u_1(t)] \\
q_2(t+1) &= q_2(t) + \Delta T [a_2(t) - \mu_2 u_2(t)] \\
q_3(t+1) &= q_3(t) + \Delta T [a_3(t) - \mu_3 u_3(t)] \\
q_4(t+1) &= q_4(t) + \Delta T [\mu_1 u_1(t) + \mu_5 u_5(t) + \mu_8 u_8(t) - \mu_4 u_4(t)] \\
q_5(t+1) &= q_5(t) + \Delta T [\alpha_{2,5} \mu_2 u_2(t) + \alpha_{3,5} \mu_3 u_3(t) - \mu_5 u_5(t)] \\
q_6(t+1) &= q_6(t) + \Delta T [\alpha_{4,6} \mu_4 u_4(t) - \mu_6 u_6(t)] \\
q_7(t+1) &= q_7(t) + \Delta T [\alpha_{4,7} \mu_4 u_4(t) - \mu_7 u_7(t)] \\
q_8(t+1) &= q_8(t) + \Delta T [\alpha_{2,8} \mu_2 u_2(t) + \alpha_{3,8} \mu_3 u_3(t) - \mu_8 u_8(t)] \\
q_9(t+1) &= q_9(t) + \Delta T [\alpha_{4,9} \mu_4 u_4(t) - \mu_9 u_9(t)] \\
q_{10}(t+1) &= q_{10}(t) + \Delta T [\alpha_{4,10} \mu_4 u_4(t) - \mu_{10} u_{10}(t)] \\
q_{11}(t+1) &= q_{11}(t) + \Delta T [\alpha_{4,11} \mu_4 u_4(t) - \mu_{11} u_{11}(t)] \\
q_{12}(t+1) &= q_{12}(t) + \Delta T [\mu_6 u_6(t) + \mu_9 u_9(t) - \mu_{12} u_{12}(t)] \\
q_{13}(t+1) &= q_{13}(t) + \Delta T [\mu_7 u_7(t) + \mu_{10} u_{10}(t) - \mu_{13} u_{13}(t)] \\
q_{14}(t+1) &= q_{14}(t) + \Delta T [\mu_{11} u_{11}(t) - d_1(t)] \\
q_{15}(t+1) &= q_{15}(t) + \Delta T [\mu_{12} u_{12}(t) - d_2(t)] \\
q_{16}(t+1) &= q_{16}(t) + \Delta T [\mu_{13} u_{13}(t) - d_3(t)]
\end{aligned} \tag{1}$$

where

$\Delta T$  is the sampling time;

$q_i(t) \geq 0$  is a queue length of containers waiting to be processed (in TEU),  $i = 1, \dots, 16$ ;

$\alpha_{i,j} \geq 0$  is a sharing percentage from the queue  $i$  to the queue  $j$ ; recall that  $\sum_j \alpha_{i,j} = 1 \quad \forall i$ ;

$a_i(t) \geq 0$  (in TEU/h) is an arrival rate of containers,  $i = 1, 2, 3$ ;

$d_i(t) \geq 0$  (in TEU/h) is a departure rate of containers,  $i = 1, 2, 3$ ;

$\mu_i \geq 0$  (in TEU/h) is a container handling capacity,  $i = 1, \dots, 13$ ;

$u_i(t) \geq 0$  is a control variable,  $i = 1, \dots, 13$ .

The parameters  $\mu_1$  and  $\mu_3$  denote container unloading rates of the cranes from ships and trains, while  $\mu_2$  is relevant to the processing rates of arriving trucks at the gate.  $\mu_4$  refers to containers handling towards the ship in the quay,  $\mu_5$  and  $\mu_8$  containers handling towards the ship in the yard,  $\mu_6$  and  $\mu_9$  towards trucks in the yard,  $\mu_7$  and  $\mu_{10}$  towards rail in the yard. Finally, the parameters  $\mu_{11}$  and  $\mu_{13}$  denote container loading rates on ships and trains, whereas  $\mu_{12}$  is associated with the waiting time of outgoing trucks at the gate. It is to be noted that queues  $q_8$ ,  $q_9$  and  $q_{10}$ , standing for containers that need to be opened and worked in the yard, are represented with the same equations used for queues  $q_5$ ,  $q_6$  and  $q_7$  which, on the contrary, are for handled containers only. As a matter of fact, their difference is only modelled assigning to the container handling capacity, that is  $\mu_i$ , a greater value for the former queues than for the latter, in order to represent the fact that opening and working a container need more time.

To sum up, in the proposed model, the queue lengths  $q_i(t)$ ,  $i = 1, \dots, 16$ ,  $t \geq 0$  represent the state variables, whereas  $u_i(t)$ ,  $i = 1, \dots, 13$ ,  $t \geq 0$  represent control variables. The constraints

**Le Gosier, Guadeloupe, June 13-18, 2004**

on the positivity of both state variables and control inputs are obvious, but some additional requirements are necessary, i.e.,

$$u_i(t) \leq 1, \quad i = 1, \dots, 13, \quad \forall t \quad (2)$$

$$q_i(t) \leq q_{i\max}, \quad i = 1, \dots, 16, \quad \forall t \quad (3)$$

$$q_5(t) + q_6(t) + q_7(t) \leq Y_{\max}, \quad \forall t \quad (4)$$

$$q_8(t) + q_9(t) + q_{10}(t) \leq W_{\max}, \quad \forall t \quad (5)$$

$$\mu_i u_i(t) \leq q_i(t), \quad i = 1, \dots, 13, \quad \forall t \quad (6)$$

Constraints (2) enable to account that no more than the maximum handling capacity is available. Constraints (3) model the obvious fact that the space in the terminal is limited. In particular, constraints (4) and (5) are necessary for representing both the limited space in the yard and the separation, in the yard, between containers to be opened and worked and containers to be handled only. Constraints (6) impose that containers leaving the queue  $i$  are less than or equal to those stocked in the queue itself.

### 3 The control scheme

A discrete-time *receding-horizon* (RH) control scheme [1] is here proposed and defined as follows. First of all, define the *finite-horizon* (FH) cost function as

$$J^{FH}(\underline{q}(t), \underline{u}(t, t+N-1)) = \sum_{j=t}^{t+N-1} \underline{1}^T \underline{q}(j), \quad t \geq 0 \quad (7)$$

where  $\underline{q}(t) \triangleq \text{col}(q_i(t), i = 1, \dots, 16)$  is the state vector,  $\underline{u}(t) \triangleq \text{col}(u_i(t), i = 1, \dots, 13)$  is the control vector,  $\underline{u}(t, \tau) \triangleq \text{col}(\underline{u}(t), \dots, \underline{u}(\tau))$ ,  $\underline{1} \triangleq \text{col}(1, 1, \dots, 1)$ , and  $N$  is a positive integer corresponding to the length of the control horizon. Cost function (7) is very simple with respect to other approaches (see, as instance [3]); in particular, the objective is the minimization of the queue lengths and, then, of the total transfer delay in the terminal.

Then, we can state the following problem

**Problem 1.** *At a generic time instant  $t$  and with reference to the state  $\underline{q}(t)$ , find the FH optimal feedback control sequence  $\{\underline{u}(t)^{FH^\circ}, \dots, \underline{u}(t+N-1)^{FH^\circ}, t \geq 0\}$  that minimizes cost (7) subject to (1), (2), (3), (4), (5), (6).*

□

Problem 1 has the structure of a linear mathematical programming problem that can be optimally solved by Simplex algorithm (and, thus, by standard mathematical programming software tools). Then, thanks to the RH mechanism, once the solution of Problem 1 has been achieved, only the first optimal FH control function (i.e., the one corresponding to  $j = t$ ) is actually applied to the system. This means that

$$\underline{u}(t)^{RH^\circ} \triangleq \underline{u}(t)^{FH^\circ}, \quad \forall t \geq 0 \quad (8)$$

and, more clearly, the RH control mechanism corresponds to the solution of the following problem

**Problem 2.** At every time instant  $t \geq 0$ , find the RH optimal control law  $\underline{u}(t)^{RH^\circ}$  as the first vector of the control sequence  $\underline{u}(t)^{FH^\circ}, \dots, \underline{u}(t + N - 1)^{FH^\circ}$ , solution of Problem 1 for the state  $\underline{q}(t)$ . □

The effectiveness of the proposed control scheme has been tested using real data relevant to a container terminal of an Italian port. To this end, a simulative tool implementing the control scheme has been realized by interfacing Matlab 6.5.1 framework with Lindo 6.1 mathematical programming software. More specifically, the RH mechanism working in Matlab uses the Lindo optimization kernel to solve, at every time instant, the current instance of Problem 1. The interface between the two software frameworks is developed by means of the high level interface tools Lindo API 2.0.

## References

- [1] S.S. Keerthi and E.G. Gilbert, "Optimal infinite-horizon feedback laws for a general class of constrained discrete-time systems: stability and moving-horizon approximations", *Journal of Optimization Theory and Applications*, 57, 265–293, (1988).
- [2] M. Kia, E. Shayan, and F. Ghotb, "Evaluation of the number of rehandles in container yards", *Computer Ind. Engineering*, 42, 533–540, (2002).
- [3] K. H. Kim and H. B. Kim, "Segregating space allocation models for container inventories in port containers terminals", *Int. J. Production Economics*, 59, 415–423, (1999).
- [4] C. I. Liu, H. Jula, and P. A. Ioannou, "Design, simulation, and evaluation of automated container terminals", *IEEE Trans. on Intelligent Transportation Systems*, 3, 12–26, (2002).
- [5] J. L. Poza, R. Simarro, M. A. de la Fuente, J. Sim, and A. Crespo, "Real-time control and monitoring in a container terminal", presented at the 15th Triennial World Congress, Barcelona, Spain, 2001.
- [6] A. E. Rizzoli, N. Fornara, and L. M. Gambardella, "A simulation tool for combined rail/road transport in intermodal terminals", *Mathematical and Computers in Simulation*, 59, 57–71, (2002).
- [7] M. B. Silberholz, B. L. Golden and E. K. Baker, "Using simulation to study the impact of work rules on productivity at marine container terminals", *Computers Ops. Res.*, 18, 433–452, (1991).
- [8] K. M. Van Hee and R. J. Wijbrands, "Decision support system for container terminal planning", *European J. of Operational Research*, 34, 262–272, (1988).